

**The Hermes Standard**  
for "M-to-M" in SMT Assembly

The Hermes Standard

# The Hermes Standard Change Proposal

BoardForecast

**Voting meeting:**  
23<sup>th</sup> of April 2018 (NEPCON / Shanghai)

**Requesting company:**  
ERSA GmbH



**The Hermes Standard** for vendor independent machine-to-machine communication in SMT Assembly.

## Version change:

Minor

## Service description tag:

FeatureBoardForecast

## Description:

The BoardForecast message can be used to indicate an upcoming board or product change to a downstream machine.

## Use cases:

Among others the BoardForecast may be used in following scenarios:

- Scenario 1: Anticipating a product change without a board (e.g. because upstream machine does not have stoppers / band that can be stopped).
- Scenario 2: Sending an estimated time to downstream machine until a board will be available (e.g. to allow downstream machine to choose between several upstream machines to get next available board)

## Functionality / communication sequences:

Scenario 1: Upstream machine is processing a changeover (new product type) and wants to ensure that the downstream machine is simultaneously also processing a changeover. Upstream machine also needs to check that this actually happens. It sends a BoardForecast with an (forecast-)ID, to which the Downstream machine at some point must respond with a MachineReady with the same ID. Upon receiving this MachineReady, the upstream machine can assume that the product change was successful.

Scenario 2: As BoardForecast in that case usually only gives some information to the downstream machine, several BoardForecast may be sent but error handling or checking are not needed on the side of the upstream machine. In that scenario ForecastId will not be sent.

## New / changed XML messages:

New BoardForecast message and extension of MachineReady message



## Proposed changes to standard:

### 2 Technical concept

...

#### 2.6 Handling of BoardForecast

Among others the BoardForecast may be used in following scenarios:

- Scenario 1: Anticipating a product change without a board (e.g. because upstream machine does not have stoppers / band that can be stopped).
- Scenario 2: Sending an estimated time to downstream machine until a board will be available (e.g. to allow downstream machine to choose between several upstream machines to get next available board).

Scenario 1:

Upstream machine is processing a changeover (new product type) and wants to ensure that the downstream machine is simultaneously also processing a changeover. Upstream machine also needs to check that this actually happens. It sends a BoardForecast with an (forecast-)ID, to which the downstream machine at some point must respond with a MachineReady with the same ID. Upon receiving this MachineReady, the upstream machine can assume that the product change was successful.

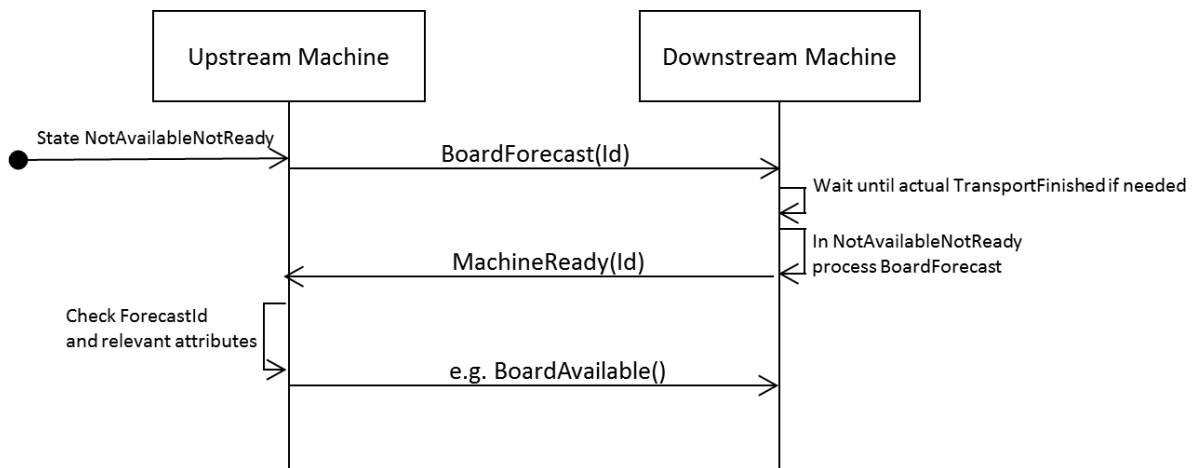

**Fig. 11 Example of communication sequence for BoardForecast**

**Notice Note:** If starting the BoardForecast handling in the state MachineReady, the downstream machine must send a RevokeMachineReady message (see Fig. 12).



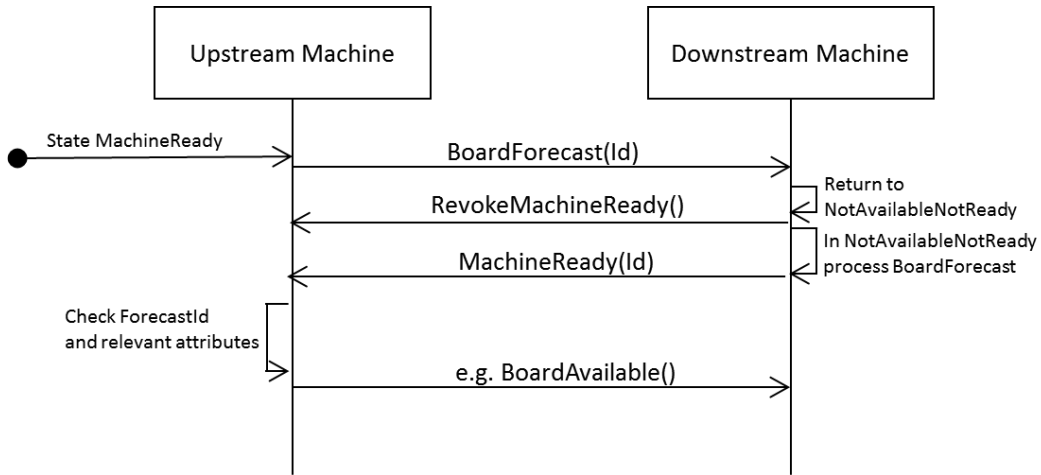

**Fig. 12 Example of communication sequence for BoardForecast with RevokeMachineReady**

If several BoardForecast messages (e.g. with different ProductTypeId) are sent in a short delay, the downstream machine may process only the last BoardForecast message:

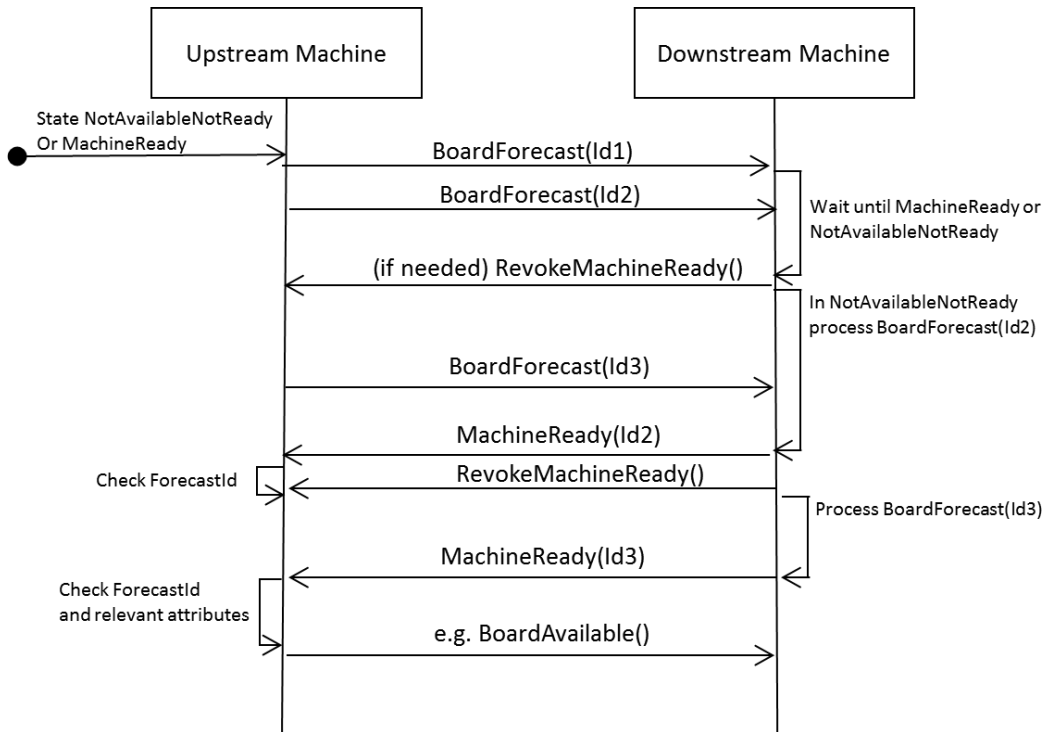

**Fig. 13 Example of communication sequence with several BoardForecast**



Scenario 1 (error handling):

If the downstream machine cannot **realise accept** the product exchange (e.g. unknown ProductId or width is physically impossible in machine) it will respond after a RevokeMachineReady with a notification of type "BoardForecastError". The upstream machine must then do some error handling (e.g. ask operator if machine should retry the BoardForecast or if the operator wants to remove the board).

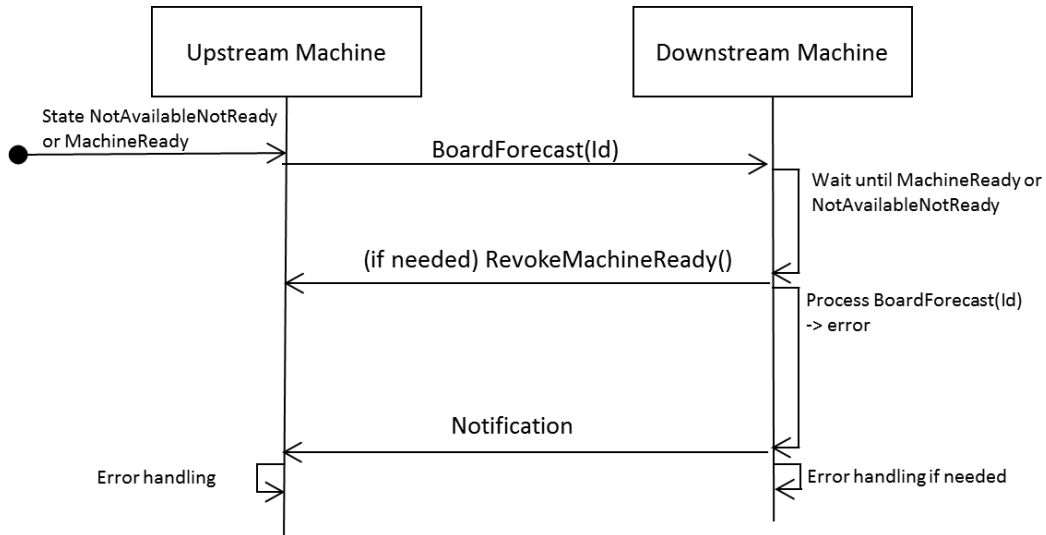

Fig. 14 Example of communication sequence in case with error handling

Scenario 2:

As BoardForecast in that case usually only gives some information to the downstream machine, several BoardForecast may be sent. However, **but** error handling or checking are not needed on the side of the downstream machine. In that scenario ForecastId will not be sent.

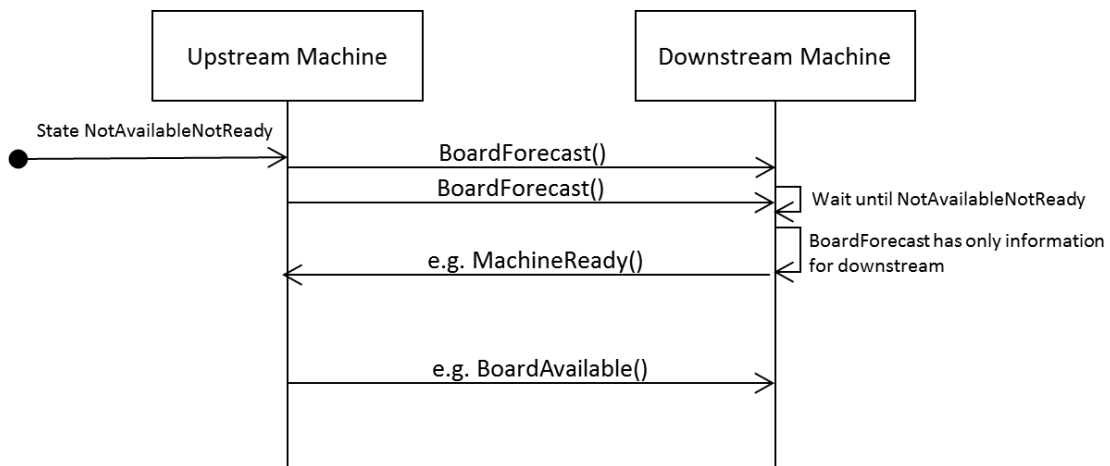
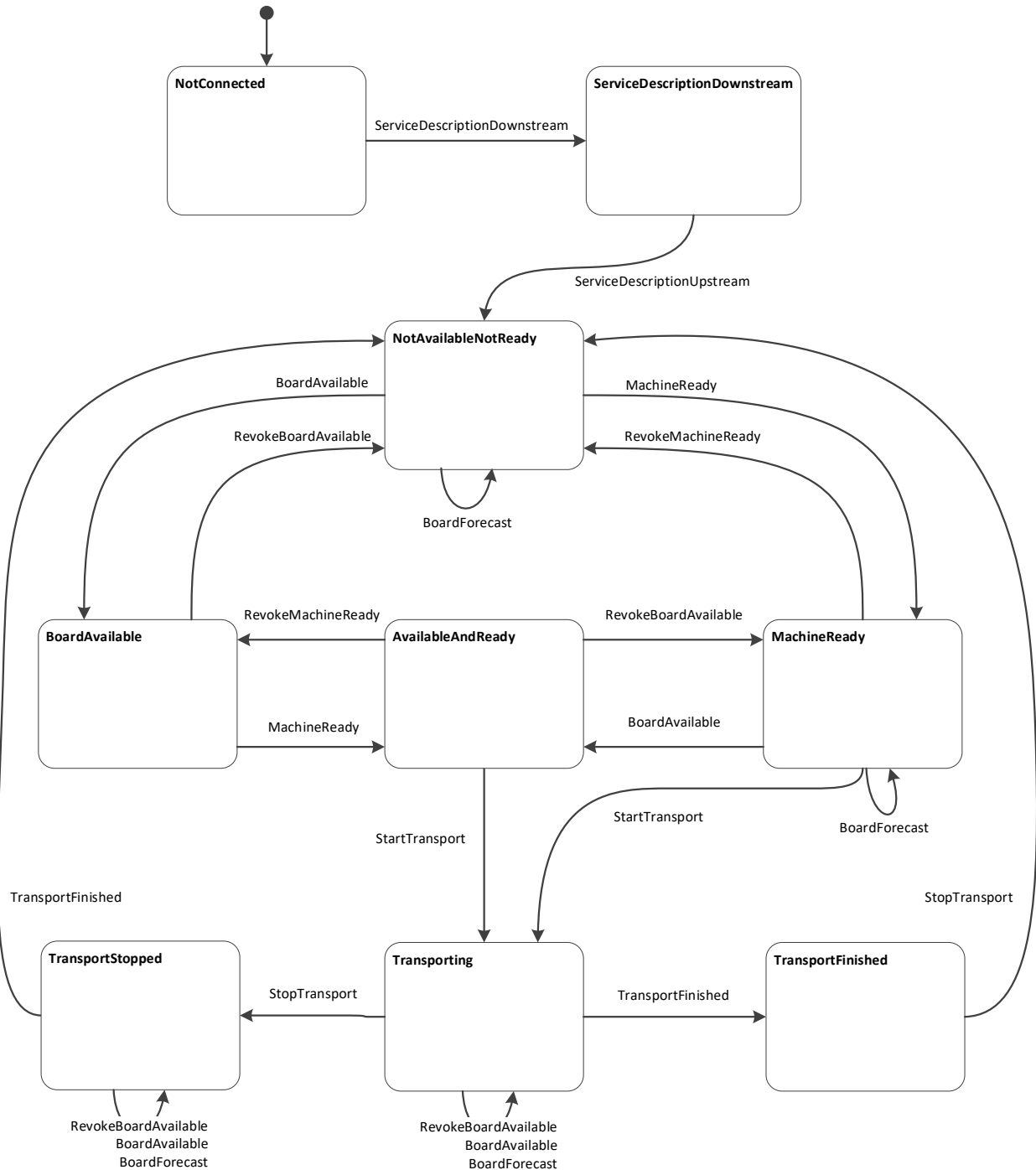

Fig. 15 Example of communication sequence BoardForecast without product change



## 2.7 Protocol states and protocol error handling



**Fig. 16 Hermes interface states**

Fig. 16 lists all states and transitions of a Hermes interface corresponding to the machine-to-machine (M2M) communication. The state is the comprehensive state of the interface rather than the state of one of the involved machines.



The messages may only be sent if they trigger the corresponding transition shown in the state chart. Any message, except "Notification" and "CheckAlive", which is received not triggering a transition is interpreted as a protocol error (e.g. a MachineReady message when the interface is in the state Transporting). In case of a protocol error, any running transport shall be stopped and the connection is terminated. The interface may start over with a new connection.

Note that due to race conditions, a RevokeBoardAvailable message may overlap with a StartTransport message or even a StopTransport message, so this shall not be treated as a protocol error (transition from MachineReady to Transporting and self-transitions on Transporting and TransportStopped).

### 3 Message definition

...

#### 3.4 ServiceDescription

The ServiceDescription message is sent by both machines after a connection is established. The downstream machine sends its ServiceDescription first whereupon the upstream machine answers by sending its own ServiceDescription.

ServiceDescription	Type	Range	Optional	Description
◆ Machinelid	string	any string	no	ID/name of the sending machine for identifying it in a Hermes enabled production line.
◆ Lanelid	int	1 .. n	no	The sending machine's lane of this connection relates to Lanes are enumerated looking downstream from right to left beginning with 1
◆ Version	string	xxx.yyy	no	The implemented interface version of the machine
📁 SupportedFeatures	Feature[]		no	List of supported features (empty for version 1.0)

The features specified in version 1.0 of this protocol have to be provided by any implementation and thus are not listed in the SupportedFeatures list of the ServiceDescription explicitly.

Feature	Type	Range	Optional	Description
📁 FeatureBoardForecast	FeatureBoardForecast		yes	In the upstream role: Machine emits BoardForecast messages. In the downstream role: Machine will respond to BoardForecast including ForecastId with a MachineReady including the same ForecastId.

#### 3.5 Notification

The Notification message is sent by both machines before a connection is terminated, e.g. after protocol errors or before shutdown. It could also be used for general notification purposes.



Notification	Type	Range	Optional	Description
◆ NotificationCode	int	1 .. n	no	A notification code of the list below. Notification codes above 1000 are not defined by this protocol and may be used by the application
◆ Severity	int	1 .. 4	no	A severity of the list below
◆ Description	string	any string	no	An English textual description of the notification.

The following NotificationCodes are defined:

- 1 Protocol error (invalid transition in the state machine, see section 2.6)
- 2 Connection refused because of an established connection
- 3 Connection reset because of changed configuration
- 4 Configuration error
- 5 Machine shutdown
- 6 **BoardForecast error**

Possible values for Severity:

- 1 Fatal error
- 2 Error
- 3 Warning
- 4 Info

### 3.8 MachineReady

The MachineReady message is sent to the upstream machine to indicate the readiness of the downstream machine to accept a PCB. or after a change / command was send with the BoardForecast Telegramm.  
In the last case the optional argument are used to ensure the change / command was executed properly.





MachineReady	Type	Range	Optional	Description
FailedBoard	int	0 .. 2	no	A value of the list below
ForecastId	string	any string	yes/no	If responding to a BoardForecast message mandatory. It indicates the ID of the original BoardForecast message.
BoardId	string	GUID	yes	Indicates the ID of the board that will be handed over as next. In case of product change this attribute will not be sent.
ProductTypeId	string	any string	yes	Identifies a collection of PCBs sharing common properties
FlippedBoard	int	0 .. 2	no	A value of the list below
Length	float	positive numbers	yes	The length of the PCB in millimeter.
Width	float	positive numbers	yes	The width of the PCB in millimeter.
Thickness	float	positive numbers	yes	The thickness of the PCB in millimeter.
ConveyorSpeed	float	positive numbers	yes	The conveyor speed used by the upstream machine in millimeter per second
TopClearanceHeight	float	positive numbers	yes	The clearance height for the top side of the PCB in millimeter.
BottomClearanceHeight	float	positive numbers	yes	The clearance height for the bottom side of the PCB in millimeter.

The attributes definition are identical to the BoardAvailable message.

FlippedBoard may be one of the following values:

- 0 Side up is unknown
- 1 Board top side is up
- 2 Board bottom side is up

FailedBoard may be one of the following values:

- 0 Ready to accept any board
- 1 Ready to accept good boards.
- 2 Ready to accept failed boards

### 3.16 BoardForecast

The BoardForecast message is sent to the downstream machine to indicate some changes / command execution are needed or to give a pre-information about the next board but a PCB is not yet available. If the ForecastId field is set then the downstream machine must at some point respond with a MachineReady carrying the same ForecastId. If needed downstream machine must send a RevokeMachineReady message



first. If the forecasted product is not fitting to the downstream machine, then it must respond with a Notification of type "BoardForecastError".

BoardForecast	Type	Range	Optional	Description
ForecastId	string	Any string	yes	Indicating the ID of forecast message. The ID must be unambiguous and e.g. can be a timestamp or a GUID.
TimeUntilAvailable	float	positive numbers	yes	Number of seconds until a board may be available at downstream machine
BoardId	string	GUID	yes	Indicating the ID of the board that will be handed over as next. e.g. in case of product change this field will not be sent
BoardIdCreatedBy	string	any string	yes	Machined of the machine which created the BoardId.
ProductTypeId	string	any string	yes	Identifies a collection of PCBs sharing common properties
FailedBoard	int	0 .. 2	no	A value of the list below
FlippedBoard	int	0 .. 2	no	A value of the list below
TopBarcode	string	any string	yes	The barcode of the top side of the next PCB
BottomBarcode	string	any string	yes	The barcode of the bottom side of the next PCB
Length	float	positive numbers	yes	The length of the PCB in millimeter.
Width	float	positive numbers	yes	The width of the PCB in millimeter.
Thickness	float	positive numbers	yes	The thickness of the PCB in millimeter.
ConveyorSpeed	float	positive numbers	yes	The conveyor speed preferred by the upstream machine in millimeter per second
TopClearanceHeight	float	positive numbers	yes	The clearance height for the top side of the PCB in millimeter.
BottomClearanceHeight	float	positive numbers	yes	The clearance height for the bottom side of the PCB in millimeter.

The attributes definition are identical to the BoardAvailable message.

FailedBoard may be one of the following values:

- 0 Ready to accept any board
- 1 Ready to accept good boards.
- 2 Ready to accept failed boards



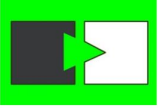

FlippedBoard may be one of the following values:

- 0 Side up is unknown
- 1 Board top side is up
- 2 Board bottom side is up

